

Manual Starters and Switches

Selection Guide

Catalog
2510CT9701R01/16

2016

Class 2510, 2511, 2512, 2601



CONTENTS

Fractional Horsepower Manual Starters—Type F	Page 3
Manual Switches—Type K	Page 6
Integral Horsepower Starters—Types M and T	Page 13
Accessories, Modifications, and Renewal Parts	Page 17
Reversing Drum Switches—Class 2601	Page 18

Manual Starters and Switches

Fractional Horsepower Manual Starters with Melting Alloy Thermal Overload Relay—Type F



Type FG2P

Fractional Horsepower Manual Starters with Melting Alloy Thermal Overload Relay—Type F

Application Data

Type F fractional horsepower starters provide overload protection as well as manual On-Off control for small motors in a variety of industrial and commercial installations. Typical applications include fans, conveyors, pumps, and small machine tools.

Both one-pole and two-pole versions are suitable for use with AC single-phase motors rated up to 1 hp. Two-pole starters can also be used with DC motors rated up to 0.75 hp.

Table 1: Electrical Ratings

Voltage Rating	277 Vac maximum (1 or 2 pole) 230 Vdc maximum (2 pole only)
Continuous Current Rating	16 A

Table 2: Horsepower Ratings

Volts	Maximum Horsepower		
	AC Single Phase		DC
	1 Pole	2 Pole	2 Pole Only
115	1	1	0.75
230	1	2	0.75
277	1	1	—

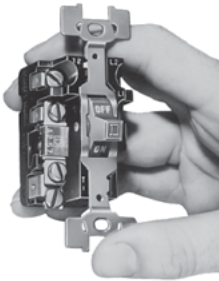

Type FO2

Enclosures: NEMA 1 surface mounting enclosures are sheet steel with a thermoplastic wrap-around cover for convenience in wiring. The NEMA 1 enclosure is also available in an oversized version that allows more space for wiring. A zinc alloy die casting is used for NEMA 4 enclosures, and a cast aluminum enclosure is offered for NEMA 3R, 7 & 9 applications.

Pilot Light: Red or green pilot light units are available factory installed in NEMA 1 surface- and flush-mounting enclosures and in NEMA 4 enclosures. They are also available as a field modification kit for NEMA 1 enclosures and gray flush plates.

For a red pilot light, use the order number as is. For a green pilot light, add a **G** to the number.

Handle Guard/Lock-Off: An optional handle guard on NEMA 1 enclosed starters prevents accidental operation of the toggle operator and allows the toggle operator to be padlocked in either the On or Off position.

The handle guard can be factory installed on NEMA 1 enclosed starters. It is also available in kit form for field installation on NEMA 1 surface- and flush-mounting enclosures. Standard NEMA 4 and NEMA 3R, 7 & 9 enclosures include provision for locking in the Off position.

Terminals: Binder head screw-type terminals are suitable for 10 AWG or smaller copper wire, and are accessible from the front. All terminals are clearly marked.

Mounting: Open types without a pilot light fit standard single-gang switch boxes, and can be used with any cover plate having a standard toggle cutout. Single-unit flush mounting types, including those with a pilot light, are suitable for wall mounting in a standard switch box or for machine cavity mounting without a box.

Operator: Available with toggle handle or with removable key-type operator to discourage unauthorized operation.

Thermal Units: Starters will not operate without a properly installed thermal unit. Install the thermal unit so that the markings face the front of the starter.

Emergency Off Actuator: A toggle operator extender is available for NEMA 1 surface-mounted units. The extender has a red vinyl button that provides a fast and easy method for locating and switching the device's toggle operator into the Off position. The Emergency Off Actuator is available in kit form only for field installation.

Manual Starters and Switches

Fractional Horsepower Manual Starters with Melting Alloy Thermal Overload Relay—Type F

Table 3: Approvals



	Enclosed Unit	Open Unit	Explosion-Proof Unit
	File E42243 CCN NLRV	—	File E58760 CCN NPXZ
	File LR25490 Class 3211 05	File LR25490 Class 3211 05	File LR26817 Class 3218 04
	—	File E42243 CCN NLRV2	—

Figure 1: Typical Wiring Diagrams

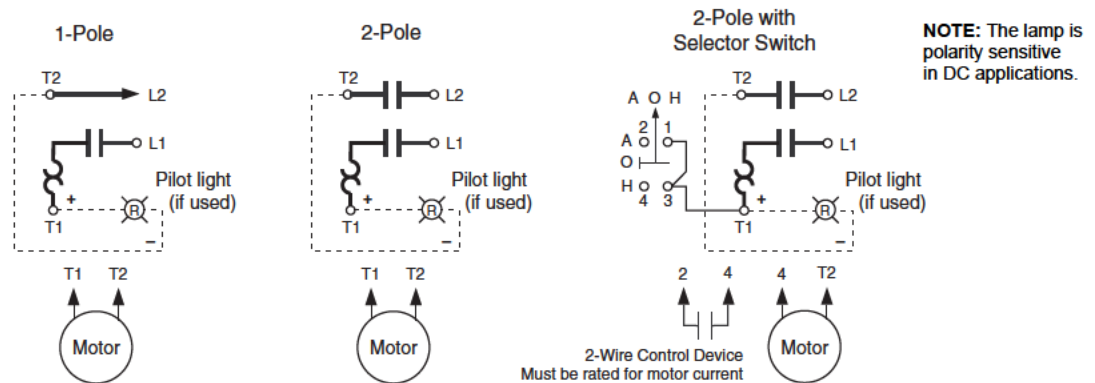

Table 4: Single-Unit Types (Class 2510)

Operator Style	No. of Poles	Features	NEMA 1 General Purpose Enclosure Surface Mounting		General Purpose Flush Mounting (Without Pull Box)			NEMA Type 4 [1] Watertight and Dusttight Enclosure	NEMA 3R, 7 & 9 [1] Enclosure Class I Groups B, C, and D Class II Groups E, F and G	Open Type	Number of Thermal Units Required
			Standard	Oversized	Gray	Standard Stainless Steel	Jumbo Stainless Steel				
Basic Starter – Class 2510											
Toggle	1	Standard	FG1	FGJ1	FF1	FS1	—	—	—	FO1	1
		With Red Pilot Light [2]	FG1P	FGJ1P	FF1P	FS1P	FSJ1P	—	—	FO1P	1
	2	Standard	FG2	FGJ2	FF2	FS2	—	—	—	FO2	1
		With Red Pilot Light [2]	FG2P	FGJ2P	FF2P	FS2P	FSJ2P	—	—	FO2P	1
Key	1	Standard	FG3	FGJ3	FF3	FS3	—	—	—	FO3	1
		With Red Pilot Light [2]	FG3P	FGJ3P	FF3P	FS3P	FSJ3P	—	—	FO3P	1
	2	Standard	FG4	FGJ4	FF4	FS4	—	—	—	FO4	1
		With Red Pilot Light [2]	FG4P	FGJ4P	FF4P	FS4P	FSJ4P	—	—	FO4P	1
Starter with Handle Guard / Lock-Off – Class 2510											
Toggle	1	Standard	FG5	FGJ5	Order basic starter plus separate handle guard kit.			FW1	FR1	FO1 [3]	1
		With Red Pilot Light [2]	FG5P	FGJ5P				FW1P	—	FO1P [3]	1
	2	Standard	FG6	FGJ6				FW2	FR2	FO2 [3]	1
		With Red Pilot Light [2]	FG6P	FGJ6P				FW2P	—	FO2P [3]	1

[1] Furnished with one 3/4" pipe tap in the bottom (reversible for top feed). To obtain a 3/4" pipe tap top and bottom, add suffix letter H to the Type number.

[2] For a green pilot light, add the letter G to the catalog number (for example, 2510FGJ2PG).

[3] When replacing a starter equipped with a pilot light in a NEMA 4 enclosure, retain the pilot light mounting bracket from the original device.

Manual Starters and Switches

Fractional Horsepower Manual Starters with Melting Alloy Thermal Overload Relay—Type F

Table 5: Duplex Units (Class 2510)

Operator Style	No. of Poles	Features	NEMA 1 General Purpose Enclosure Surface Mounting	General Purpose Flush Mounting (Without Pull Box)		Number of Thermal Units Required
				Flush Plate for Wall or Cavity Mounting		
				Gray	Stainless Steel	
One Starter in Duplex Enclosure—Class 2510						
Toggle	2	Standard	FG02	—	—	1
		With Red Pilot Light [1]	FG02P	—	—	1
Key	2	With Red Pilot Light [1]	FG04P	—	—	1
Two Starters in One Enclosure—Class 2510						
Toggle	2 per Starter	Standard	FG22	FF22	—	2
		With Red Pilot Light on Each [1]	FG22P	FF22P	FS22P	2
Key	2 per Starter	With Red Pilot Light on Each [1]	FG44P	FF44P	FS44P	2
Starter and Auto-Off-Hand SPDT Selector Switch (AC Only)—Class 2510						
Toggle	1	Standard	FG71	FF71	—	1
		With Red Pilot Light [1]	FG71P	FF71P	FS71P	1
	2	Standard	FG72	FF72	—	1
		With Red Pilot Light [1]	FG72P	FF72P	FS72P	1
Key	2	With Red Pilot Light [1]	FG74P	FF74P	FS74P	1

[1] For a green pilot light, add the letter G to the catalog number (for example, 2510FG02PG).

Table 6: Two Speed Starters (Class 2512)

Type F two-speed manual starters are designed for the control of small single-phase AC motors that have separate windings for high and low speed operation. Two toggle-operated starters are used, with overload protection included for each motor winding. Surface mounting devices, and those with a gray flush plate, utilize a mechanical interlock which allows direct control of the motor by means of the toggle operators.

Two Speed Starters, Class 2512						Replacement Starter, Class 2510	
Operator Style	No. of Poles	Features on the Standard Device	NEMA 1 General Purpose Enclosure, Surface Mounting	General Purpose Flush Mounting (Without Pull Box)		General Purpose Flush Mounting (Without Pull Box)	Number of Thermal Units Required
				Flush Plate for Wall or Cavity Mounting			
				Gray	Stainless Steel		
Toggle	1	Mechanical interlock	FG11	FF11	—	FO1T	2
		Mechanical interlock and two red pilot lights [1]	FG11P	FF11P	—	FO1PT	2
		High-Off-Low selector switch and two red pilot lights [1]	—	—	FS101P	FO1PT	2
	2	Mechanical interlock	FG22	FF22	—	FO2T	2
		Mechanical interlock and two red pilot lights [1]	FG22P	FF22P	—	FO2PT	2
		High-Off-Low selector switch and two red pilot lights [1]	—	—	FS202P	FO2PT	2

[1] For a green pilot light, add the letter G to the catalog number (for example, 2510FG02PG).

Manual Starters and Switches

Manual Switches—Type K Reversing, Non-Reversing, Two Speed



Type KG1A

Manual Switches—Type K Reversing, Non-Reversing, Two Speed

Application Data

Type K motor starting switches provide manual On-Off control of single- or three-phase AC motors, where overload protection is not required or is provided separately. These devices are suitable for use with three-phase AC motors rated up to 20 hp. Compact construction and a 600 V rating make these switches suitable for a wide range of industrial and commercial uses. Typical applications include small machine tools, pumps, fans, conveyors, and many other types of electrical machinery. They can also be used on non-motor loads such as resistance heaters.

Table 7: Electrical Ratings

Voltage Rating	600 Vac maximum 230 Vdc maximum
Continuous Current Rating	30 A at 600 Vac maximum (20 A at 600 Vac maximum for NEMA 3R and 7 & 9 enclosed) 30 A at 24 Vdc maximum

Table 8: Horsepower Ratings

Class	Type	No. of Poles	Motor Type	Maximum Horsepower				DC Rating		
				115 V	230V	460 V	575 V	90 V	115 V	230V
2510	KO1, KO3	2	1-Phase	2	2	3	3	1	2	1.5
	KO2, KO4	3	3-Phase	2	7.5	10	10	1	2	1.5
	KO5	2	1-Phase	2	3	7.5	10	1	2	1.5
	KO6	3	3-Phase	2	7.5	15	20	1	2	1.5
2511	All	2	1-Phase	2	2	3	3	1	2	1.5
		3	3-Phase	2	7.5	10	10	1	2	1.5
2512	All	2	1-Phase	2	2	3	3	1	2	1.5
		3	3-Phase Constant or Variable Torque	2	7.5	10	10	1	2	1.5
		3	3-Phase Constant Horsepower	2	7.5	10	10	1	2	1.5

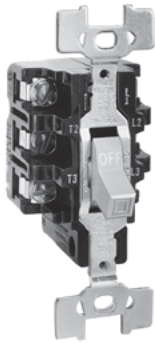

Type KO2

Enclosures: NEMA 1 surface-mounting enclosures are sheet steel with a thermoplastic wrap-around cover for convenience in wiring. The NEMA 1 enclosure is also available in jumbo and oversized versions that allow more space for wiring. A zinc alloy die casting is used for NEMA 4 enclosures, and a cast aluminum enclosure is offered for NEMA 3R and 7 & 9 applications.

Mounting: Open types without a pilot light fit standard single-gang switch boxes, and can be used with any cover plate having a standard toggle cutout. Single-unit flush-mounting types, including those with pilot light, are suitable for wall mounting in a standard switch box or for machine cavity mounting without a box. For difficult wall surfaces, such as concrete block or tile, a jumbo size flush plate is recommended. See the dimensional drawings for additional details and mounting provisions of enclosed types.

Pilot Light: Red or green pilot light units are available factory installed in NEMA 1 surface- and flush-mounting enclosures and in NEMA 4 enclosures. They are also available as a field modification kit for NEMA 1 enclosures and gray flush plates.

For a red pilot light, use the order number as is. For a green pilot light, add a **G** to the number.

Operator: Available with a toggle handle or with a removable key-type operator to discourage unauthorized operation.

Emergency Off Actuator: A toggle operator extender is available for NEMA 1 surface-mounting units. The extender has a red vinyl button that provides a fast and easy method for locating and switching the device's toggle operator into the Off position. The Emergency Off actuator is available in kit form only for field installation.

Manual Starters and Switches

Manual Switches—Type K Reversing, Non-Reversing, Two Speed

Table 9: Approvals



	Enclosed Unit	Open Unit	Explosion-Proof Unit
	File E42243 CCN NLRV	—	File E58760 CCN NPXZ
	File LR25490 Class 3211 05	File LR25490 Class 3211 05	File LR26817 Class 3218 04
	—	File E42243 CCN NLRV2	—

Figure 2: Typical Wiring Diagrams

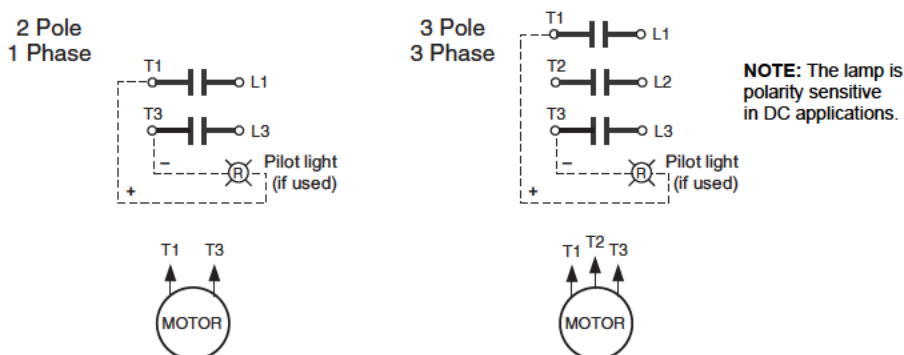

Table 10: Non-Reversing (Class 2510)

Operator Style	No. of Poles	Features	NEMA 1 Enclosure					NEMA 4 [1] Enclosure Watertight and Dusttight	NEMA 3R, 7 & 9 [1] Enclosure Class I Groups B, C and D Class II Groups E, F, and G	Open Type	
			General Purpose, Surface Mounting		General Purpose, Flush Mounting (Without Pull Box)						
			Standard	Oversized	Gray	Standard Stainless Steel	Jumbo Stainless Steel				
Toggle	2	Standard	KG1	KGJ1	KF1	KS1	—	KW1	KR1	KO1	
		With Pilot Light [2] 115 Vac 230 Vac	KG1A KG1B	KGJ1A KGJ1B	KF1A KF1B	KS1A KS1B	KSJ1A KSJ1B	KW1A KW1B	— —	KO1A [3] KO1B [3]	
	3	Standard	KG2	KGJ2	KF2	KS2	—	KW2	KR2	KO2	
		With Pilot Light [2] 208–277 Vac 440–600 Vac	KG2B KG2C	KGJ2B KGJ2C	KF2B KF2C	KS2B KS2C	KSJ2B KSJ2C	KW2B KW2C	— —	KO2B [3] KO2C [3]	
	2	Standard	KG5	KGJ5	—	—	—	KW5	—	KO5	
		With Pilot Light [2] 115 Vac 230 Vac	KG5A KG5B	— —	— —	— —	— —	KW5A KW5B	— —	KO5A KO5B	
	3	Standard	KG6	KGJ6	—	—	—	KW6	—	KO6	
		With Pilot Light [2] 208–277 Vac 440–600 Vac	KG6B KG6C	— —	— —	— —	— —	KW6B KW6C	— —	KO6B KO6C	
	Key	2	Standard	KG3	KGJ3	KF3	KS3	—	—	—	KO3
			With Pilot Light [2] 115 Vac 230 Vac	KG3A KG3B	KGJ3A KGJ3B	KF3A KF3B	KS3A KS3B	KSJ3A KSJ3B	— —	— —	KO3A KO3B
		3	Standard	KG4	KGJ4	KF4	KS4	—	—	—	KO4
			With Pilot Light [2] 208–277 Vac 440–600 Vac	KG4B KG4C	KGJ4B KGJ4C	KF4B KF4C	KS4B KS4C	KSJ4B KSJ4C	— —	— —	KO4B KO4C

[1] Furnished with one 3/4" pipe tap in the bottom (reversible for top feed). For a 3/4" pipe tap on the top and bottom, add suffix H to the Type number.

[2] For a green pilot light, add the letter G to the catalog number (for example, 2510KG2BG).

[3] Do not use as replacement interiors for NEMA 4 devices. For a replacement unit, order Type KO1 or KO2 and a separate pilot light kit. (Be sure to retain the pilot light mounting bracket from the original device.)

Manual Starters and Switches

Manual Switches—Type K Reversing, Non-Reversing, Two Speed



File E42243
CCN NLRV2



File LR25490
Class 3211 05

Table 11: Reversing (Class 2511)

Type K reversing manual switches provide a compact means of starting, stopping, and reversing AC motors where overload protection is not required or is provided separately. They are suitable for use with three-phase squirrel cage motors and for single-phase motors that can be reversed by reconnecting motor leads. Two switches are used, one to connect the motor for forward rotation and one for reverse.

Operator Style	No. of Poles	Suitable Motor Types	Features (Includes Mechanical Interlock)	NEMA 1 General Purpose Enclosure Surface Mounting	With Flush Plate for Cavity Mounting (Without Pull Box)	Replacement Switch Class 2510
Toggle	2	Single Phase, 3-Lead Repulsion-Induction	Standard	KG11	KF11	KO1T
			With Pilot Light ^[1] 115 Vac 230 Vac	KG11A KG11B	KF11A KF11B	KO1AT KO1BT
	3	Three Phase; also Single Phase Capacitor, Split Phase, or 4-Lead Repulsion-Induction	Standard	KG22	KF22	KO2T
			With Pilot Light ^[1] 110–120 Vac 208–220 Vac 440–600 Vac	KG22A KG22B KG22C	KF22A KF22B KF22C	KO2AT KO2BT KO2CT

^[1] For a green pilot light, add the letter G to the catalog number (for example, 2511KF11AG).

Table 12: Two Speed (Class 2512)

Type K two-speed manual switches can be used with separate winding three-phase or single-phase AC motors, where overload protection is not required or is provided separately. Two switches provide On-Off control in each speed.

Operator Style	No. of Poles	Suitable Motor Types	Features (Includes Mechanical Interlock)	NEMA 1 General Purpose Enclosure Surface Mounting	With Flush Plate for Cavity Mounting (Without Pull Box)	Replacement Switch Class 2510
Toggle	2	Single Phase, Two Winding (3-Lead)	Standard	KG11	KF11	KO1T
			With 2 Pilot Lights ^[1] 115 Vac 230 Vac	KG11A KG11B	KF11A KF11B	KO1AT KO1BT
	3	Three Phase, Separate Winding (Wye-Connected)	Standard	KG22	KF22	KO2T
			With 2 Pilot Lights ^[1] 208–240 Vac 440–600 Vac	KG22B KG22C	KF22B KF22C	KO2BT KO2CT

^[1] For a green pilot light, add the letter G to the catalog number (for example, 2512KF11AG).

Manual Starters and Switches Approximate Dimensions, Types F and K

Approximate Dimensions, Types F and K

Figure 3: Type F Fractional Horsepower, Open Type
Dimensions are typical for key operator devices.

Type FO2

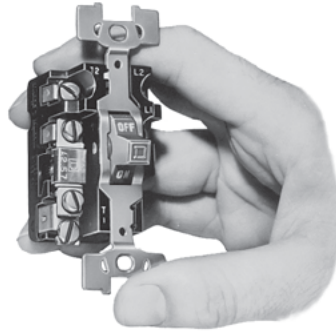

Types FO1, 1P, 2
Fractional Hp Starter

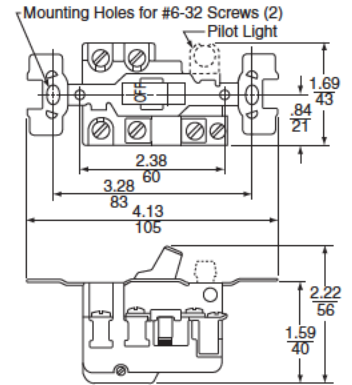
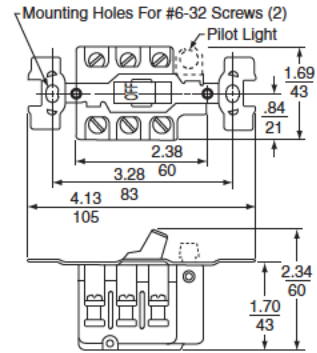

Figure 4: Type K Motor Starting Switch, Open Type
Dimensions are typical for key operator devices.



**Figure 5: Dimensions for NEMA 1 General Purpose, Surface-Mounting Enclosures
Standard Size**



Type FG2P

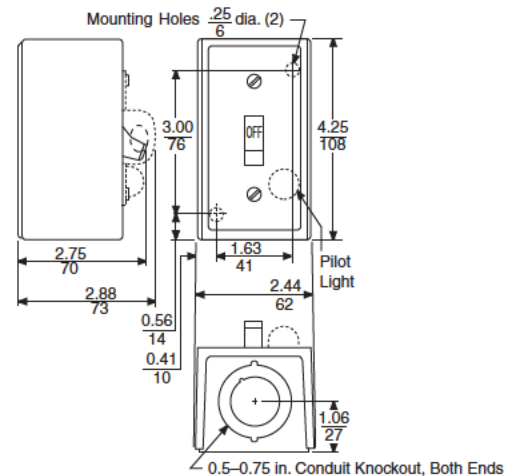

Manual Starters and Switches

Approximate Dimensions, Types F and K

Figure 6: Dimensions for NEMA 1 General Purpose Surface Mounting Enclosures—Oversized

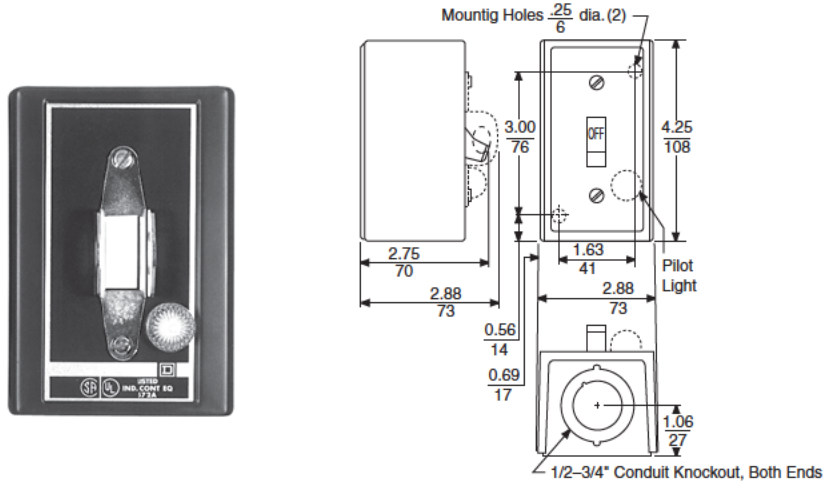

Figure 7: Dimensions for NEMA 1 General Purpose, Surface-Mounting Enclosures—Jumbo Size

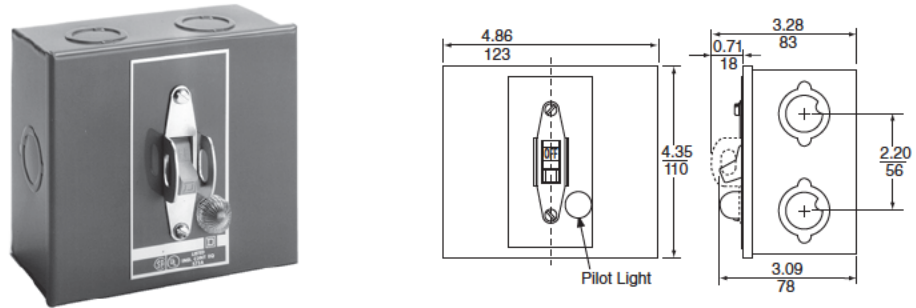
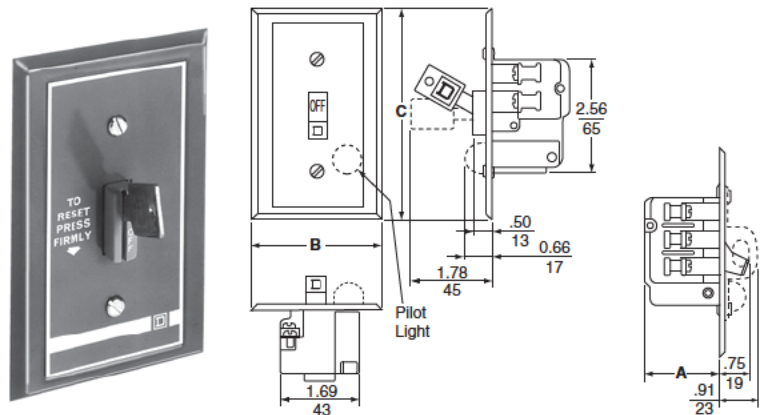

Table 13: Dimensions for General Purpose, Flush-Mounting

Device	Operator Style	Class 2510 Type	Dimensions (in.)		
			A	B	C
Type F	Toggle	FF1, 1P, 2, 2P	1.44	2.75	4.5
		FS1, 1P, 2, 2P	1.44	3.5	5.25
	Key	FF3, 3P, 4, 4P	1.44	2.75	4.5
		FS3, 3P, 4, 4P	1.44	3.5	5.25
Type K	Toggle	KF1, 1A, 1B	1.75	2.75	4.5
		KF2, 2B, 2C			
		KS1, 1A, 1B			
	Key	KS2, 2B, 2C	1.75	3.5	5.25
		KSJ1A, 1B			
		KSJ2B, 2C			
Key	KF3, 3A, 3B	1.75	2.75	4.5	
	KF4, 4B, 4C				
	KS3, 3A, 3B				
Key	KS4, 4B, 4C	1.75	3.5	5.25	
	KSJ3A, 3B				



Manual Starters and Switches Approximate Dimensions, Types F and K

Figure 8: Dimensions for NEMA 3R, 7, and 9 Cast Aluminum Enclosure for Hazardous Locations



**Class 2510 Type KR2H
NEMA 3R, 7 & 9
Weight: 3.5 lb**

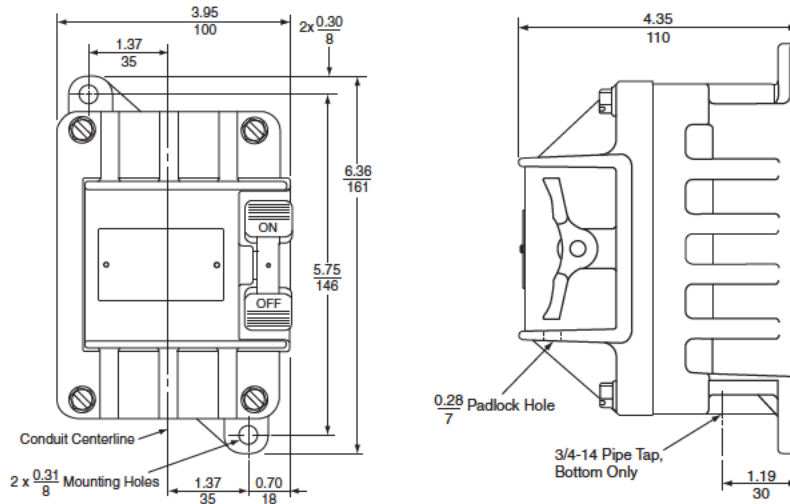

Device	Class	Type
Type F	2510	FR1, 2
Type K	2510	KR1, 2

Figure 9: Dimensions for NEMA 4 Watertight Die Cast Zinc Enclosure



**NEMA 4
Weight: 3.0 lb**

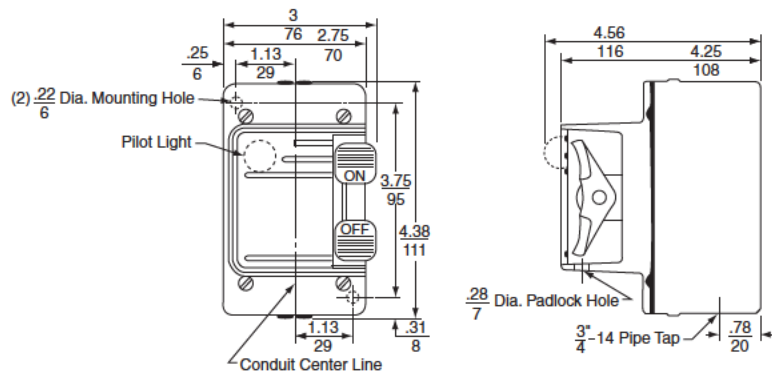

Device	Class	Type
Type F	2510	FW1, 1P, 2, 2P
Type K	2510	KW1, 1A, 1B KW2, 2B, 2C KW5, 5A, 5B KW6, 6B, 6C

Table 14: Two-Unit Devices—NEMA 1 General Purpose Enclosure

Device	Operator Style	Class	Type
One Starter	Toggle	2510	FG02, FG02P
	Key	2510	FG04P
Two Starters	Toggle	2510	FG22, FG22P
	Key	2510	FG44P
One Starter and One Selector Switch [1]	Toggle	2510	FG71, FG71P, FG72, FG72P
	Key	2510	FG74P
Reversing Switch [2]	Toggle	2511	KG11, KG11A, KG11B, KG22A, KG22B, KG22C
Two-Speed Starter	Toggle	2512	FG11, FG11P, FG22, FG22P
Two-Speed Switch	Toggle	2512	KG11, KG11A, KG11B, KG22, KG22B, KG22C

[1] The selector switch is on the left. It increases the overall depth to 3.5 in.
 [2] Only one pilot light (located on the right) is used on Class 2511 switches.

See the dimensional drawings in Figure 10 on page 12.

Manual Starters and Switches

Approximate Dimensions, Types F and K

Figure 10: Dimension Drawing for Two-Unit NEMA 1 General Purpose Enclosure

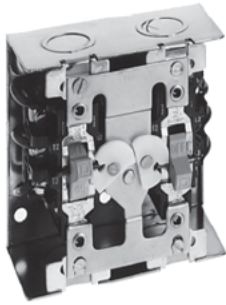

Class 2511 Type KG22
(Cover Removed)



Class 2511 Type KG22
(Cover)

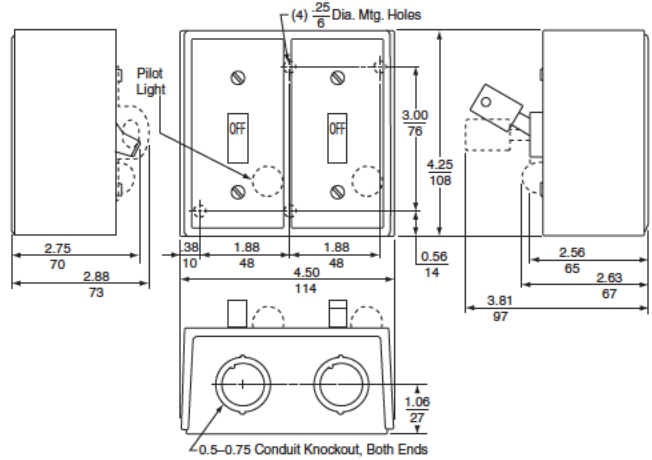

Table 15: Two-Unit General Purpose Flush Mounting Plate

Device	Operator Style	Class	Type	Dimensions			
				A	B	C	D
Two Starters	Toggle	2510	FF22, FF22P	5.25	3.75	5.25	1.44
			FS22P	4.56	3.5	4.5	1.44
	Key	2510	FF44P	5.25	3.75	5.25	1.44
			FS44P	4.56	3.5	4.5	1.44
One Starter and One Selector Switch [1]	Toggle	2510	FF71, FF71P, FF72, FF72P	5.25	3.75	5.25	2.0
			FS71P, FS72P	4.56	3.5	4.5	2.0
	Key	2510	FF74P	5.25	3.75	5.25	2.0
			FS74P	4.56	3.5	4.5	2.0
Reversing Switch [2]	Toggle	2511	KF11, KF11A, KF11B KF22, KF22A, KF22B, KF22C	5.25	3.75	5.25	1.75
Two-Speed Starter	Toggle	2512	FF11, FF11P, FF22, FF22P	5.25	3.75	5.25	1.44
Two-Speed Switch	Toggle	2512	KF11, KF11A, KF11B KF22, KF22B, KF22C	5.25	3.75	5.25	1.75



Class 2512 Type KF22

[1] The selector switch is on the left and extends 1.63 in. from the mounting surface.
[2] Dimensions include factory-wired power connections.

Figure 11: Dimension Drawing for Two-Unit General Purpose Flush Mounting Plate

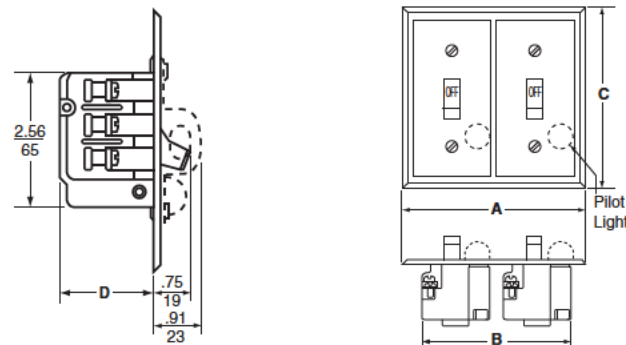

Manual Starters and Switches

Class 2510, 2511, 2512 Integral Horsepower Starters—Types M and T

Class 2510, 2511, 2512 Integral Horsepower Starters—Types M and T



**Class 2510
Type M and T
in General Purpose
Enclosure**

Application Data

Types M and T integral horsepower manual starters provide convenient On-Off operation of small single-phase, polyphase, or DC motors. Typical applications include small machine tools, pumps, fans, and conveyors. They feature push button or toggle operators and reliable overload protection. Pilot lights and auxiliary contacts are available. For modifications, see page 17.

Size: Available in NEMA Sizes M-0, M-1, and M-1P

Poles:

AC: Two poles single-phase; three poles polyphase

DC: 2 poles (3 poles in series)

Voltage Rating: 600 Vac maximum, 250 Vdc maximum

Overload Relays: Melting alloy thermal overload relays have provisions for one Type B thermal unit for single-phase starters, or three Type B thermal units for three-phase starters. *All thermal units must be installed, and the device reset, before the starter contacts will operate.* After an overload relay trips, wait one or two minutes before resetting to allow the alloy to solidify.

Operator: Open and NEMA 1 versions are available with a push button or toggle operator. NEMA 4 and 12 are available with a direct-acting push button only. NEMA 4X and 7 & 9 use an external toggle to actuate a push button device inside.

Mechanism Lock Off: Open devices and starters in the following enclosures can be locked in the Off or Stop position: NEMA 1 surface and flush mounting; and NEMA 4, 4X, 7 & 9, and 12 .

Devices in the following enclosures can also be locked closed to prevent unauthorized entry: NEMA 1 surface mounting; and NEMA 4, 4X, and 12 . NEMA 7 & 9 enclosures are bolted closed.

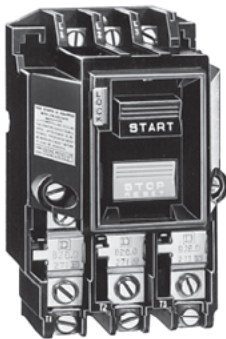

**Size M-1, 3-Pole
Push Button Operated**

Table 16: Terminals

NEMA Size	Power Terminals		Auxiliary Interlock Terminals	
	Type of Lug	Wire Range Solid or stranded copper wire	Type of Lug	Wire Range Solid or stranded copper wire
M-0	Pressure Wire	14–8	Pressure Wire	16–12
M-1	Pressure Wire	14–8	Pressure Wire	16–12
M-2	Box Lug	14–6	Pressure Wire	16–12

Approvals

All Except
NEMA 7 & 9



File E42243
CCN NLRV



File LR60905
Class 3211 05

NEMA 7 & 9 Only



File E78503
CCN NPXZ



File LR60905
Class 3218 04

Table 17: Maintenance of Equipment

For proper performance, all equipment should be periodically inspected and maintained. Replacement contacts and interlocks are available in kit form to facilitate servicing and stocking. In addition, the instruction bulletin listed in the following table contains an exploded view of the device with components clearly marked for easy identification by description and part number.

NOTE: Consult instruction bulletin 30072-013-19 (312AS).

NEMA Size	Number of Poles	Replacement Contact Kit
		Class 9998, Type
M-0	2 or 3	ML1
M-1	2 or 3	ML2
M-1P	2	ML2

Manual Starters and Switches

Class 2510, 2511, 2512 Integral Horsepower Starters—Types M and T



**NEMA 4/4X
Watertight and Dusttight
Stainless Steel**

Accessories and Modification Kits: One auxiliary contact, either N.O. or N.C., can be easily added internally to any open or enclosed Type M or T manual starter. It occupies the space provided in either the upper right or left corners of the device. These contacts are for AC loads only.

A unique red pilot light assembly that clips into place is available factory-installed on NEMA 1, 4, 4X, 12, and flush enclosures. The assembly is also available as a field modification kit for NEMA 1 surface or flush mounting enclosures. The color cap assembly snaps into a knockout in the enclosure cover on the NEMA 1 enclosures. Pilot light kits are available for use on various voltages, 110–600 V. (Pilot light assemblies are not available for NEMA 7 & 9 enclosures.)

Class 2511 reversing manual starters consist of two mechanically interlocked Class 2510 Type M or T manual starters. They are available in NEMA 1 surface-mounting enclosures or as open type.

Class 2512 two-speed manual starters are for wye-connected separate winding motors only. They consist of two mechanically interlocked Class 2510 Type M or T manual starters.

Starters will not operate unless the thermal units have been properly installed (with the markings facing the front of the starter) and the device has been reset.

Table 18: Class 2510 Device Type Numbers—Non-Reversing, Integral Horsepower Manual Starters, 600 Vac Maximum

No. of Poles	NEMA Size	Ratings			NEMA Enclosure						Open Style	
		Motor Voltage	Max. HP		NEMA 1 Surface Mounting		NEMA 4/4X Watertight, Dusttight, and Corrosion-Resistant		NEMA 7 & 9 [1] for Hazardous Locations Class I Grps C, D Class II Grps E, F, G	NEMA 12 [2] Dusttight and Driptight Industrial Use	Square Push Button Operator	Toggle Operator
			Poly-Phase	Single Phase	Square Push Button Operator	Toggle Operator	Brushed Stainless Steel	Glass Polyester				
2 Pole	M-0	115 230	—	1 2	MBG1	TBG1	MBW11 [3]	MBW1 [3]	MBR1 [3]	MBA1 [3]	MBO1	TBO1
	M-1	115 230	—	2 3	MCG1	TCG1	MCW11	MCW1	MCR1	MCA1	MCO1	TCO1
	M-1P	115 230	—	3 5	MCG2	TCG2	MCW12	MCW2	MCR2	MCA2	MCO2	TCO2
3 Pole	M-0	115 200–230 380–575	—	3 5	MBG2	TBG2	MBW12 [3]	MBW2 [3]	MBR2 [3]	MBA2 [3]	MBO2	TBO2
	M-1	115 200–230 380–575	—	7.5 10	MCG3	TCG3	MCW13	MCW3	MCR3	MCA3	MCO3	TCO3
DC 2 Pole	M-0	115 230	1 hp, DC 1.5 hp, DC	—	MBG4	TBG4	MBW14	MBW4	—	MBA4	MBO4	TBO4
	M-1	115 230	1.5 hp, DC 2 hp, DC	—	MCG5	TCG5	MCW15	MCW5	MCR5	MCA5	MCO5	TCO5

[1] For NEMA 7 & 9, these Type numbers are for cast-iron enclosures. For outdoor use, NEMA 4X and 7 & 9 cast-aluminum enclosures are available; to order these enclosures, replace the R in the Type number with a T. For additional information, contact your local Square D™ field sales office.

[2] NEMA 12 enclosures can be field modified for outdoor applications.

[3] Approved for group motor installations in accordance with NEC 430-53(c).

Table 19: Class 2511 Device Type Numbers—Reversing Manual Starters

Number of Poles	NEMA Size	Ratings		NEMA 1 Surface Mounting		Open Type	
		Motor Voltage	Maximum Horsepower	Square Push Button Operator	Toggle Operator	Square Push Button Operator	Toggle Operator
3 Pole	M-0	200–230	3	MBG1	TBG1	MBO1	TBO1
		380–575	5				
	M-1	200–230	7.5	MCG1	TCG1	MCO1	TCO1
		380–575	10				

Table 20: Class 2512 Device Type Numbers—Two-Speed Manual Starters

Number of Poles	NEMA Size	Ratings			NEMA 1 Surface Mounting		Open Type	
		Motor Voltage	Constant Horsepower	Constant or Variable Torque	Square Push Button Operator	Toggle Operator	Square Push Button Operator	Toggle Operator
3 Pole	M-0	200–230	2	3	MBG1	TBG1	MBO1	TBO1
		380–575	3	5				
	M-1	200–230	5	7.5	MCG1	TCG1	MCO1	TCO1
		380–575	7.5	10				



**NEMA 12
Driptight and Dusttight
Industrial Use**

Manual Starters and Switches

Class 2510, 2511, 2512 Integral Horsepower Starters—Types M and T

Figure 12: Dimensions for Class 2510 Starters



NEMA 4/4X
Watertight, Dusttight, and
Corrosion-Resistant
Glass Polyester

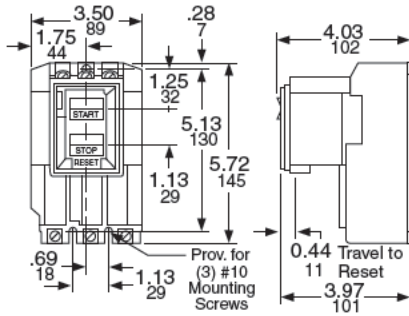

Class 2510 Type M, Open Style
Sizes M-0, M-1, M-1P
Approximate Shipping Weight: 3 lb

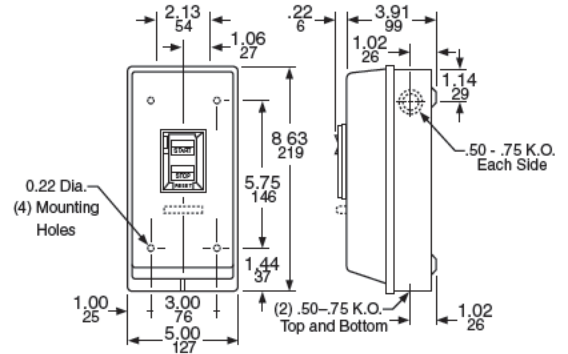

Class 2510 Types M and T, Sizes M-0 and M-1
NEMA 1 General Purpose Enclosure
Approximate Shipping Weight: 5 lb

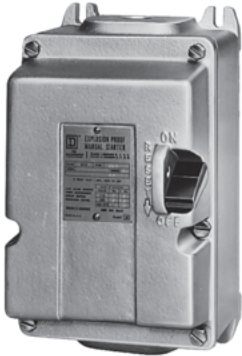

NEMA 7 & 9
Hazardous Location
Cast Iron

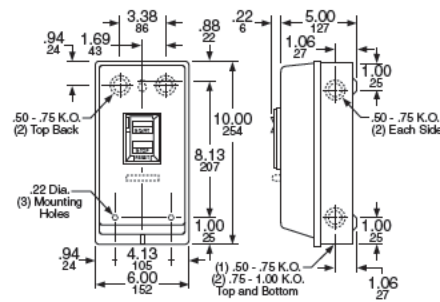

Class 2510 Types M and T, Size M-1P
NEMA 1 General Purpose Enclosure
Approximate Shipping Weight: 5 lb

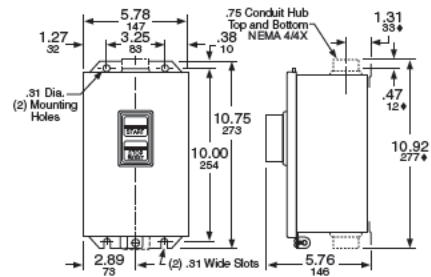

Class 2510 Type M Sizes M-0, M-1, and M-1P
NEMA 4/4X Watertight Stainless Steel Enclosure
NEMA 12 Dusttight Industrial Use Enclosure
Approximate Shipping Weight: 9 lb

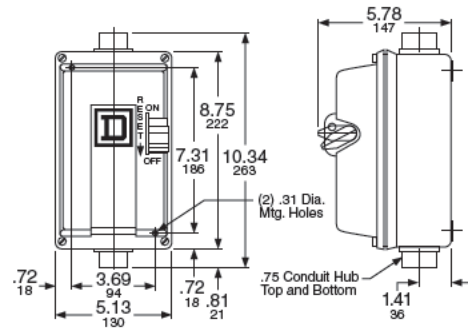

Class 2510 Type M, Size M-0 (AC or DC) and M-1 (DC)
NEMA 4/4X Watertight, Corrosion-Resistant
Glass Polyester Enclosure
Approximate Shipping Weight: 6 lb

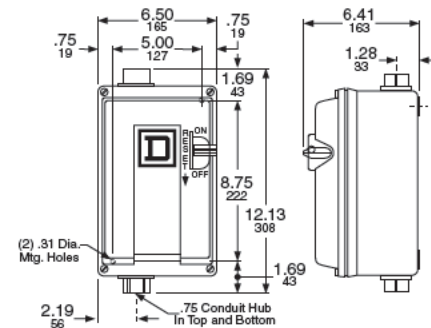

Class 2510 Type M Sizes M-1 and M-1P (AC)
NEMA 4/4X Watertight, Corrosion-Resistant
Glass Polyester Enclosure
Approximate Shipping Weight: 6 lb

Manual Starters and Switches

Class 2510, 2511, 2512 Integral Horsepower Starters—Types M and T

Figure 13: Dimensions for Class 2510, 2511, and 2512 Starters

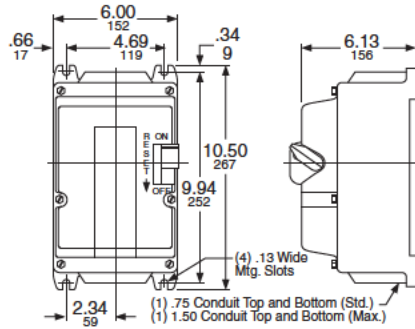

Class 2510 Type M, Sizes M-0, M-1, and M-1P
NEMA 7 & 9 Hazardous Location
Cast Iron Enclosure
Approximate Shipping Weight: 18 lb

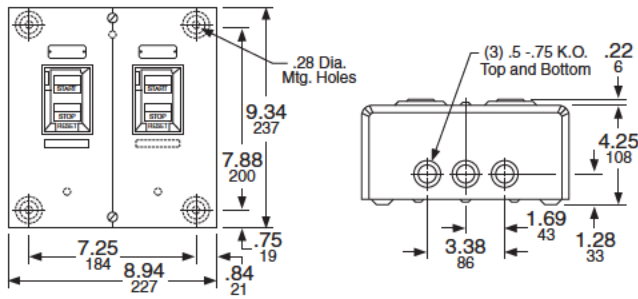

Class 2511 and 2512 Types M and T
Sizes M-0 and M-1
NEMA 1 General Purpose Enclosure
Approximate Shipping Weight: 9 lb

Accessories, Modifications, and Renewal Parts

Table 21: Accessories for Class 2510 Types F and K

Description	Class and Type
Handle Guard Kit with Padlock Provision [1]	2510 FL1
Emergency Off Actuator	2510 PB1
Additional Key for Key Operated Devices	2510 FK1

[1] Standard on Type K devices.

Table 22: Replacement Parts

Description	Class and Type
Replacement Toggle Kits: Type FW and KW (NEMA 4) Type FR and KR (NEMA 7 & 9)	9998 HW1 9998 HR2
Replacement Handle Kits: Type MBA, MCA, MBW, MCW (NEMA 4 and 12) Type MBR, MCR, MBW, MCW (NEMA 4X, 7 & 9)	9998 HWA1 9998 HR3
Internal Lever	9998 L1

Table 24: Pilot Light Kits for Class 2510 Types F and K

Application	Voltage	Class and Type	
		Pilot Light	
		Red	Green
Type KF, KG, KW [1]	110–120 Vac	9999PL11	9999PL11G
	208–277 Vac	9999PL12	9999PL12G
	440–600 Vac	9999PL13	9999PL13G
Type FF or FG	115–240 Vac/Vdc	9999PL10	9999PL10G

[1] The lens cannot be replaced. Kits for NEMA 4 replacement only.

Table 26: P11 Pilot Light Voltage Codes for Class 2510, 2511, and 2512, Type M and T

Voltage	Code
120 V	V02
200/208 V	V08
230 V	V03
460 V	V06
575 V	V07

Table 23: Replacement Nameplates for Class 2510 Types F and K

Description	Application	Nameplate Marking	Nameplate Type Number—Class 2510			
			For Type K Switch		For Type F Starter (Includes Reset Indication)	
			Pilot Light			
			Without	With	Without	With
1-3/4" x 2-13/16" Nameplate with Embossed Mounting Holes for #6 Oval Head Screws	Standard commercial switch box cover or flush plate, including Square D™ stainless steel plates	Blank	FN1	—	FN2	—
		Special marking (specify the marking)	FN5	—	FN6	—
1-29/32" x 3-27/32" Flat Nameplate with Mounting Holes for #6 Pan Head Screws	Square D NEMA 1 surface mounted enclosure or gray flush plate	Blank	FN10	FN20	FN30	FN40
		High	FN11	FN21	FN31	FN41
		Low	FN12	FN22	FN32	FN42
		Forward	FN13	—	—	—
		Reverse	FN14	FN24	—	—
		Special marking (specify the marking)	FN15	FN25	FN35	FN45

Table 25: Enclosures

For use with Class 2510 Type	Enclosure	Catalog No.
F and K	NEMA 1 Standard	9991EN1
M: Sizes M-0 and M-1		9991MG1
M: Size M-1P		9991MG2
MBO and MCO	NEMA 1 Flush Mounting with pull box and plaster adjustment	9991MF1
	NEMA 1 Flush Mounting without pullbox but with mounting strap	9991MF2
	NEMA 4/4X (Polyester)	9991MW1
	NEMA 4/4X (Stainless Steel)	9991MW11
FO1, FO1P, FO2, FO2P, FO3, FO3P, FO4, FO4P	NEMA 1 Oversized	9991FE1
KO1, KO1A, KO1B, KO2, KO2B, KO2C, KO3, KO3A, KO3B, KO4, KO4B, KO4C, KO5, KO5A, KO5B, KO6, KO6B, KO6C	NEMA 1 Oversized	9991KE1
	NEMA 1 Jumbo	9991KE2
	NEMA 3R	9991KE3

Table 27: Modifications (Types M and T Only)

Description	Factory Modifications Form Number	Field Modifications Kit Class and Type
Red Pilot Light [1]	P11 [2]	9999MP1 (110–120 V) 9999MP2 (208–240 V) 9999MP3 (440–600 V)
Auxiliary Contacts [3]	X1 (1 N.O.) X2 (1 N.C.)	9999SX11 (N.O.) 9999SX12 (N.C.)
Jumper Straps [4]	N/A	9998SO31
Contactors Only	Y76 (does not change starter dimensions)	N/A

[1] Can only be field-added to NEMA 1 enclosures.

[2] P11 pilot lights require a voltage code.

[3] For proper operation, only one auxiliary contact kit per device is allowed to be added.

[4] For controlling a single-phase motor with a three-phase starter.

Manual Starters and Switches

Class 2601 Reversing Drum Switches

Class 2601 Reversing Drum Switches



Type AG2

Reversing drum switches are designed to start and reverse motors by connecting them directly across-the-line. The devices can be used with squirrel cage motors; single-phase motors designed for reversing service; and series, shunt, and compound DC motors. The applications should be such that across-the-line starting of the motors is not objectionable, unless other means is provided for limiting starting current and torque. Class 2601 drum switches are field convertible from maintained to momentary operation.

Application Data

The reversing drum switches are particularly suited for use in manual reversing control applications such as machine tools, woodworking machines, and similar types of equipment. Examples include lathes, milling machines, planers, grinders, shapers, and boring mills. Other possible applications include door operators, small hoists, and conveyor belts.

Overload and low-voltage protection are not incorporated into these reversing drum switches. Should the power fail, the contacts will remain closed unless assembled for momentary operation, and the handle will stay in the selected position. The motor will restart when the power returns.



Type AW2

Voltage	600 Vac Maximum 250 Vdc Maximum
Contact Mechanism	Large movable contact segments are rigidly attached to the main operating shaft. They are fully insulated from each other and from the shaft. Stationary contact fingers are mounted in polymeric blocks. Both movable and stationary contacts are plated for maximum life. Easily accessible terminals are provided to simplify wiring. Type A is provided with screw-type terminals and Type B is provided with pressure-wire connector terminals. Contacts are not replaceable.
Operating Mechanism	The operating mechanism is factory assembled for Maintained Position operation. That is, when the handle is moved to the forward or reverse position, it will remain there until moved. The mechanism can easily be converted to provide Spring-Return-to-Off operation, with no additional parts needed. This conversion is accomplished by removing the handle screw and handle, turning the shaft 180 degrees, and then replacing the handle and handle screw.
Handles	Both the NEMA 1 and NEMA 4 devices come standard with a one-piece molded handle.
Enclosures	The polymeric NEMA 1 enclosure is suitable for indoor applications when normal atmospheric conditions prevail. The NEMA 4 enclosure is suitable for applications requiring watertight and dusttight capabilities. Generous wiring space is provided in both types. Two knockouts or openings for 1/2 in. conduit entries are located in the bottom plate of Types AG and BG, while two 1/2 in. conduit entries with hubs come standard on Types AW and BW. A single captive screw holds the cover on NEMA 1 enclosures, while three captive screws hold the cover on NEMA 4 enclosures. Removing the cover allows free access to three sides of the switch mechanism. Large, legible nameplates are securely attached to the enclosures to clearly indicate switching positions and to provide complete rating information. An instruction sheet showing typical motor connections is also included.

Manual Starters and Switches Class 2601 Reversing Drum Switches

Table 28: Class 2601 Device Types—NEMA 1, 4, and 13—without Overload Protection

Volts	Ratings			Device Type, 600 Vac Maximum		Device Type, 360 Vdc Maximum	
	Maximum Horsepower			Enclosure		Enclosure	
	AC 1-Phase	AC Polyphase	DC	NEMA 1 General Purpose	NEMA 4 Watertight and Dusttight	NEMA 1 Maintained and Momentary [1]	NEMA 13 Oiltight Flush Mounting
115 200/230 230 460/575	1.5 — 2 —	— 2 — 2	0.25 — 0.25 —	AG2	AW2	AG2S2	AF2
115 200/230 230 460/575	1.5 — 3 5	— 5 — 7.5	2 — 2 —	BG1	BW1	—	—

[1] Maintained-Forward; Momentary-Reverse. Not field convertible.

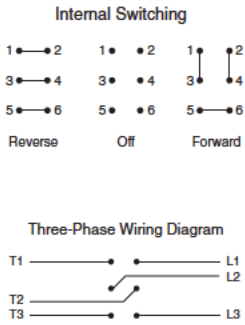
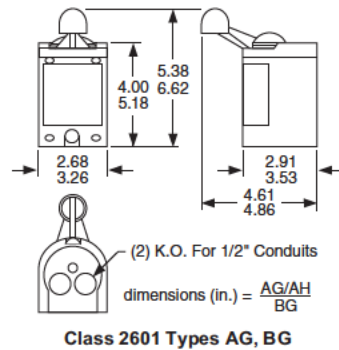
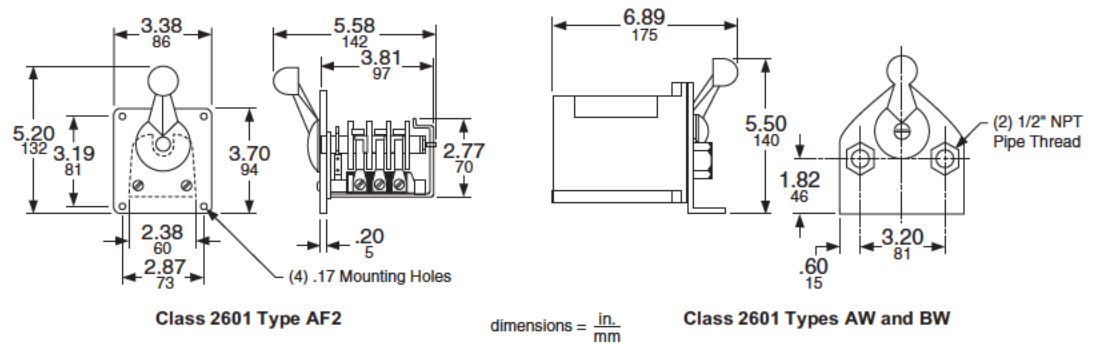

Figure 14: Approximate Dimensions

 File E42243
CCN NLRV

 File LR25490
Class 3211 05



Schneider Electric USA, Inc.
800 Federal Street
Andover, MA 01810 USA
888-778-2733
www.schneider-electric.us

Schneider Electric and Square D are trademarks and the property of Schneider Electric SE, its subsidiaries, and affiliated companies. All other trademarks are the property of their respective owners.

2510CT9701R01/16 Replaces 2510CT9701, 12/1997
© 1997–2016 Schneider Electric All Rights Reserved